

48"

1 BACK VIEW
SCALE: 1" = 1'-0"

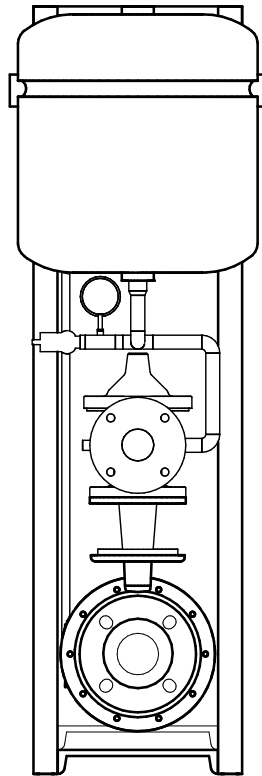

2 FRONT VIEW
SCALE: 1" = 1'-0"

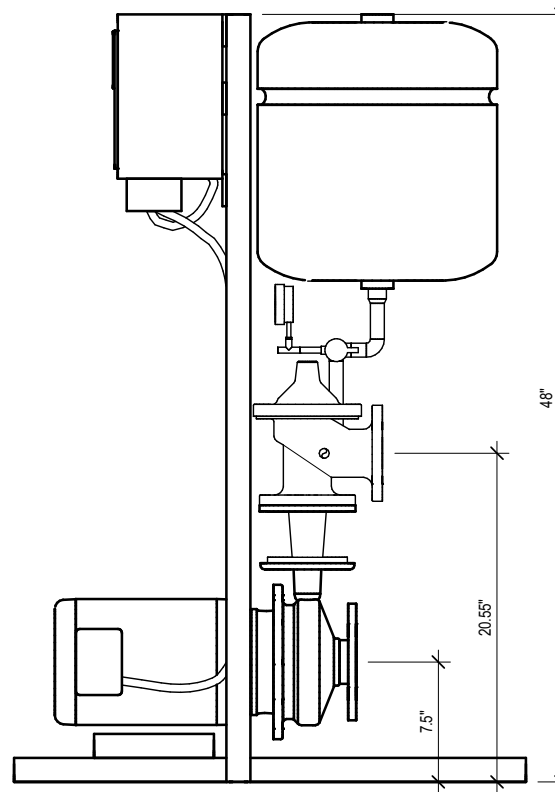

48"

20.55"

7.5"

3 SIDE VIEW
SCALE: 1" = 1'-0"

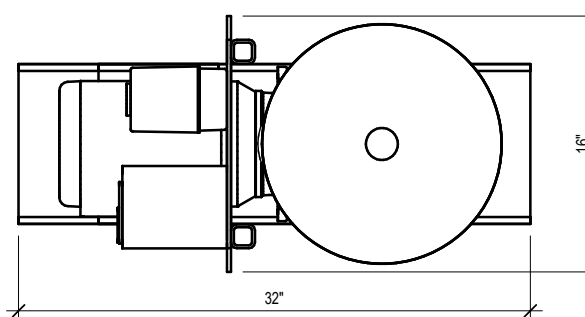

16"

32"

4 PLAN VIEW
SCALE: 1" = 1'-0"

WATER PRESSURE BOOSTER SYSTEM

SERIES: POSI-BOOST MODULAR WATER PRESSURE BOOSTER SYSTEM
NOMINAL WEIGHT: 200LBS

MANUFACTURER	MODEL NUMBER	GPM	TDH	HP	RPM
PENN PUMP CO	PB-750	-	-	7.5	3600

BILL OF MATERIAL

ITEM NO.	DESCRIPTION	QUANTITY
1	STAINLESS STEEL END SUCTION PUMP - 7.5HP	1
2	IQ VFD CONTROLLER - 7.5HP	1
3	NEMA 4X DISCONNECT SWITCH	1
4	2" ANGLE CHECK VALVE	1
5	4-20MA, 0-200PSI TRANSDUCER	1
6	0-160PSI PRESSURE GAUGE	1
7	THERMAL PURGE VALVE - SET TO 105°F	1
8	PRESSURE RELIEF VALVE - SET TO 125PSI	1
9	10 GALLON HYDROPNEUMATIC TANK - 150PSI RATED	1

FIELD CONNECTIONS

ITEM NO.	DESCRIPTION	QUANTITY
A	SUCTION CONNECTION - 2.5" 150LBS RF	1
B	DISCHARGE CONNECTION - 2" 150LBS RF	1
C	PRESSURE RELIEF VALVE - 3/4" NPT	1
D	THERMAL PURGE VALVE - 1/4" NPT	1
E	ELECTRICAL CONNECTION - VARIES	1

GENERAL NOTES:

- FACTORY TEST AND PAINT WITH TWO COATS OF SHOP ENAMEL
- SYSTEM DRAIN AND VENT CONNECTIONS AS REQUIRED
- SYSTEM FLEXIBLE CONNECTORS SHIP LOOSE WHEN PURCHASED WITH SYSTEM
- NOT FOR CONSTRUCTION PURPOSES UNLESS CERTIFIED

REV	DESCRIPTION	DATE	APPROVED
-	REVISIONS	-	-

PENN PUMP & EQUIPMENT COMPANY, INC.	DRAWN BY: B-CAD CHECKED BY: DC ISSUE DATE: 11/19/2021	DATE: 11/19/2021 DATE: 11/19/2021	POSI-BOOST 7.5HP BOOSTER SYSTEM		REV: 0
	APPROVED BY: DC DATE: 11/19/2021	SCALE: NONE			DWG NO: - SHEET 1 OF 1