

INSTALLATION OPERATION & MAINTENANCE INSTRUCTIONS

FOR YOUR

PENN PUMP & EQUIPMENT COMPANY, INC.

WATER BOOSTER SYSTEM

This completely assembled, tested, packaged pumping system is of the highest quality and design. To obtain optimum performance from this system, it is important that you read these instructions carefully and pay particular attention to any highlighted instructions. We are confident that you will receive many years of trouble-free service from your **Penn Pumping System**.

www.pennpump.com

I. GENERAL DESCRIPTION

The Penn Pump Water Booster System is completely assembled and consists of one, two, three, or more centrifugal pumps operating in parallel with valves, controls, and piping designed to maintain a suitable water pressure in the area it serves over a wide and varying flow range.

II. RECEIVING AND TEMPORARY STORAGE

A. RECEIVING

1. Check pumping unit for shortage and damage immediately upon arrival. Pump accessories, when required, are packaged in a separate container and shipped with the unit.
2. If equipment is damaged in transit, promptly report this to the carrier's agent. Make complete notations on the freight bill to speed satisfactory adjustment by the carrier.
3. Unload and handle the unit with a sling. Do not lift the unit by eye bolts on the motor!

B. TEMPORARY STORAGE

1. If pump is not to be installed and operated soon after arrival, store it in a clean, dry area of moderate ambient temperature – approximately 50°F.
2. Rotate the shaft by hand periodically to coat bearing with lubricant, which will retard oxidation and corrosion.
3. Follow motor manufacturer's storage recommendations where applicable.

III. SETTING IN PLACE

- A. INSTALLATION-** install in a location that allows accessibility for maintenance and inspection. Keep the suction piping oversized, simple, and with as few turns as possible. Allow at least 36" of clear space in front of the panel extending down to the floor to comply with the National Electric Code requirements for electric control panels.
- B. ANCHORING-** This pumping unit should be leveled and bolted to a firm foundation.
- C. PIPING-** System isolation valves should be installed on both the suction and discharge of the packaged system. A customer-installed bypass is also frequently called for to facilitate maintenance. Avoid any points in the piping that might create air pockets and throttle the flow. At no point should the suction piping be smaller than the suction header connection. **DO NOT FORCE PIPING WHEN MAKING CONNECTIONS.** Use pipe hangers or other supports. Both suction and discharge piping should be independently supported and properly aligned so that **NO STRAIN IS TRANSMITTED TO THE UNIT** when the flange bolts are tightened. Install flexible piping connectors to avoid piping stress caused by system or piping movement. Pipe all safety relief valves and thermal safety valves to an adequate drain.

IV. TIGHTENING CONNECTIONS

All piping and wiring is factory tested. Handling during transit, off-loading, and installations can loosen the connections; therefore, tightening some connections may be required.

V. CONNECTING POWER SOURCE

The unit will operate under the following conditions:

- A. The voltage can be 10% (+ / -) of the motor nameplate data

Install electrical wiring in accordance with NEC standards and any local regulations. The line voltage and wire amp capacity must match the voltage and the full load amps of all motors in the system.

CAUTION

ENSURE THAT THE POWER SUPPLY THAT WILL FEED THE BOOSTER SYSTEM CONTROL PANEL IS DISCONNECTED BEFORE PROCEEDING WITH THE FOLLOWING STEPS.

1. Place panel disconnects and H-O-A switches in the off position.
2. Open the panel, visually check components for any shipping damage, and verify that all power leads are secure.
3. Connect power supply leads to the main power terminals. The main terminals are located in the enclosure and are identified as L1, L2, L3. Also refer to the wiring diagram inside of the enclosure.
4. The unit must be securely grounded, per National Electric Code.
5. Switch main power supply disconnect to "On". This will provide power to the terminal block of the control panel. Verify that the power supply agrees with the booster control panel voltage.

NOTE: If not proceeding with start up at this time, disconnect power supply to the panel.

VI. PRE STARTUP REVIEW AND INSPECTION

Before starting the system, it is important to review the following booster system data sheets. Each system is custom fabricated, incorporating a variety of components. Review the system construction, options, control sequencing, panel features, and operation of your system. It is essential to have a detailed understanding of the system. After a thorough study of these instructions, a close visual inspection of the system is recommended.

VII. CHECK OUT OF PUMPS, VALVES TANK

- A. Verify that electric power and water are available.
- B. If your system incorporates a hydropneumatic tank, refer to the tank information regarding charging.
- C. The tank must be charged to 5psig below the lead pump "On" setting. Always soap all tank connections to verify that no air is leaking through any of the tank fittings.
- D. All isolation valves including the main suction and discharge valves must be in the closed position.

- E. Rotate the pumps by hand, if possible. They should turn freely.
- F. Open the main suction valve on the inlet to the system manifold and verify the suction pressure against the specifications.
- G. Slowly open the suction valve to one pump at a time and check the pump unit and fittings for leaks.
- H. Vent each pump casing, if applicable, by loosening a pipe plug at the highest point to ensure that no air is trapped, which would cause a seal failure and pump vapor lock.
- I. Slowly open the pump discharge valve one pump at a time. Check fittings for leaks. **DO NOT OPEN MAIN DISCHARGE VALVE OUTLET OF THE SYSTEM MANIFOLD AT THIS TIME.**

VIII. ELECTRICAL CHECK OUT

CAUTION

DO NOT PROCEED UNTIL REQUIREMENTS OF “CONNECTING POWER SOURCE” (ITEM IV) HAVE BEEN COMPLETED.

- A. Confirm that the suction pressure is adequate.
- B. Energize power supply to panel, if necessary.
- C. Verify pumps are full and completely vented.
- D. Ensure H-O-A selector(s) are in OFF position.
- E. Turn disconnect(s) only to ON position; door must be closed.
- F. Any alarm conditions during the power activation should be silenced and reset.
- G. Jog each pump by turning the respective H-O-A switches momentarily to the “HAND” position and verify correct rotation. End suction pumps rotate in the clockwise direction when viewed from the motor end. Correct rotational direction for other type pumps is usually indicated with an arrow. Close-coupled pumps usually can be viewed from the motor end to verify rotation. If pump rotation needs to be reversed, correct as follows.

CAUTION

Ensure that power supply to the Booster System control panel is disconnected before proceeding with the following steps.

- H. If all motors rotate counter clockwise, swap any two of the three power leads from the VFD to the motor.

IX. SYSTEM START UP

- A. Verify that the system piping in the building can be pressurized. Open a valve or fixture at the highest point to release the air in the system.
- B. Open the main discharge valve on the outlet of the system manifold.
- C. Close each individual pump discharge valve.
- D. Start pump #1 in the "HAND" position.
- E. Slowly open the pump discharge valve.
- F. Fill the entire building system and observe the high point fixture until all the air is released and then close the fixture.
- G. Open one or more plumbing fixtures in close proximity. Ideally, have a hose bib or janitor's sink downstream of the booster system.
- H. Close all plumbing fixtures to stop water flow.
- I. Turn pump to "OFF" position.
- J. Check to determine if the system pressure remains stable. Failure to remain stabilized indicates an improperly operating check valve or plumbing system leakage. Confirm all isolation valves are fully open.
- K. Turn all H-O-A switches to the "AUTO" position. The system is now operating in the fully automatic mode. All control devices can be adjusted to meet field conditions.

X. MAINTENANCE

Periodic maintenance requirements are minimal. The mechanical seals used on the pumps do not require periodic maintenance. Some larger electric motors may be equipped with bearing grease fittings. In the absence of specific instructions on the motor, these fittings should be greased every six months with the relief plug removed.

HYDROPNEUMATIC TANK START-UP PROCEDURE

1. Inspect the tank for damage, which may have occurred during shipping.
2. Most tanks are shipped with a factory precharge of 12psig. Check the precharge using an accurate pressure gauge at the charging valve. The pressure should be within + or – 3 pounds depending on the ambient temperature.
3. If any damage exists or the precharge is not acceptable, contact Penn Pump & Equipment Company, Inc. immediately. **DO NOT INSTALL UNIT.**
4. To install the tank, set the unit in place and connect the system piping to the system connection on the tank. **DO NOT REMOVE BOTTOM PLUG OR LOOSEN NUT ON COVER PLATE.** The bottom plug and cover plate are to be removed only in the event of bag failure. Removing the bottom plug or loosening the cover nut plate will result in the loss of factory precharge and a void warranty.
5. The unit must be charged to the desired precharge before the system is filled with water. Recommended charge is approximately 5lbs. psi below pump on pressure.
6. **LEAK CHECK ALL CONNECTIONS INCLUDING COVER PLAGE SEAL DURING ADJUSTMENT OF PRECHARGE AND INITIAL OPERATION OF UNIT.**
7. When filling system with water, any valves in the line leading to the tank must be open to ensure that the water displaces any trapped air in the tank. Be sure to follow the manufacturer's stamp procedures for other components in the system.

WARRANTY

The components of each Penn Pump water pressure booster system, when purchased as regular factory selections, are warrantied against failure due to defects in design, material, or construction, from date of factory shipment within the periods and under the conditions noted below:

PUMPS

All Penn Pump pumping assemblies are warrantied against mechanical failure for a period of One (1) year. If any component of the pumping assembly fails within this period, Penn Pump & Equipment Company, Inc., will, at its option, repair or replace the pump assembly on a no-charge exchange basis FOB factory, Hatfield, Pennsylvania.

MOTORS

Motors, when equipped with standard Penn Pump overload protection systems and maintained according to factory instructions, are warrantied for One (1) year. Penn Pump & Equipment Company, Inc., will make, at its option, a no-charge repair or replacement at the factory or at the authorized motor service station.

COMPLETE SYSTEM

The complete Penn Pump system as a whole, including all accessories and components not mentioned above, is warrantied functionally and mechanically for a period of One (1) year, when installed, operated, and maintained in accordance with the Company's recommendations.

Penn Pump & Equipment Company, Inc., is responsible only for repairing or replacing its products in accordance with the terms and conditions set forth above. There are no warranties, either expressed or implied, extending beyond those stated on the face hereof, and Penn Pump & Equipment Company, Inc. expressly disclaims all other warranties, including any implied warranties of mechanical ability or fitness for a particular purpose. Penn Pump & Equipment Company, Inc. also disclaims any liability whatsoever for incidental or consequential damages, including damages to property, damages for loss of use, loss of time, loss of profits, loss of income, or any other incidental or consequential damages. Penn Pump & Equipment Company, Inc. neither assumes nor authorizes any other person to furnish any warranties, or assume for it any liability in connection with the sale of its products.

This warranty does not include mechanical seals, gauges, transportation, or labor costs for exchange or installation or repaired or replaced material. Final determination of warranty shall be made only by the factory upon return and inspection of returned material. No material is to be returned without a return of materials authority (RMA) tag which may be obtained by calling or writing the factory, advising what will be shipped and the reason for the return.

2100 Series – 3500 RPM

304SS, 60 Hz

Construction Options

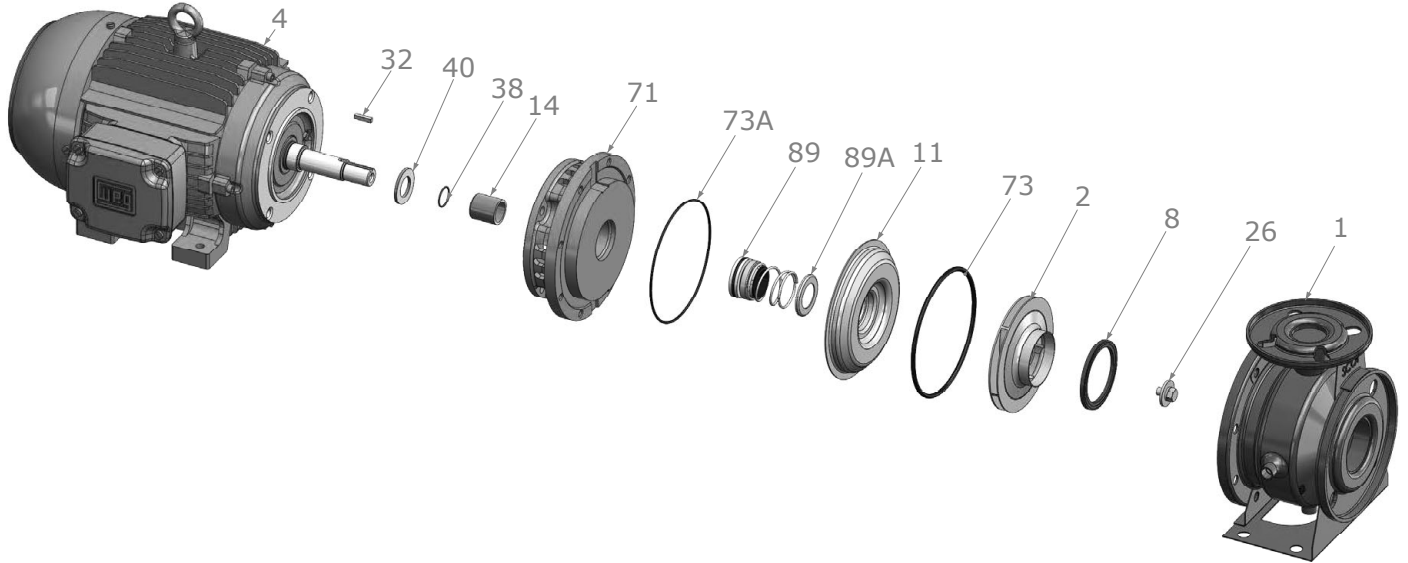

Construction Options		
Key No.	Part Name	Standard Fitted
1	Case	304SS
2	Impeller	304SS
8	Impeller Ring	PPO-20
11	Cover	304SS
14	Sleeve	304SS
26	Impeller Retaining Assembly	304SS
32	Key	303SS
38	Gasket Shaft	Buna
40	Flinger	304SS
71	Motor Disc	Iron
73	Gasket, Case	Buna
73A	Gasket, Cover	Buna
89	Seal Assembly BN-CARB/CM	Standard
89A	Seal Spring Retainer	304SS